

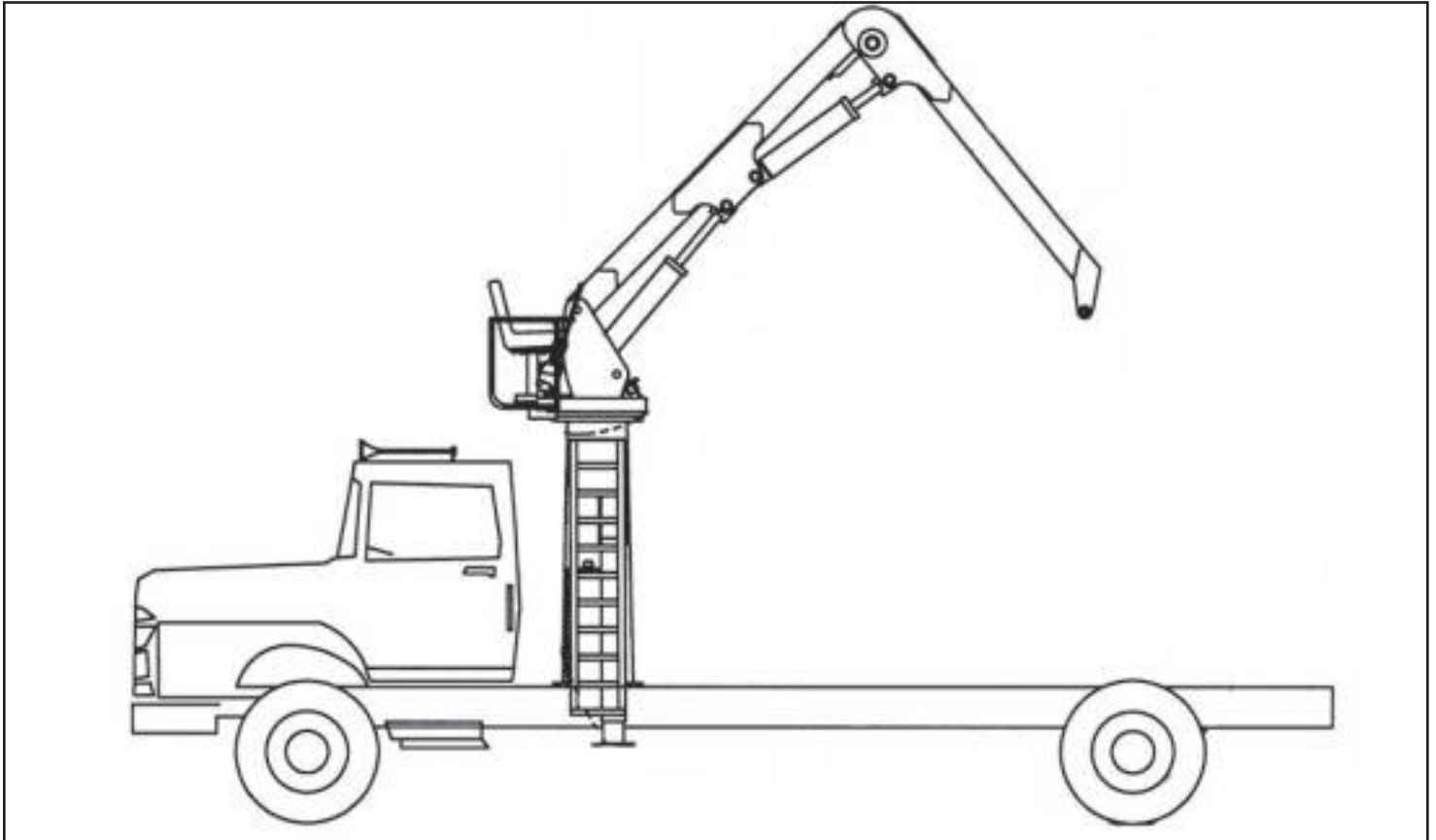

**BUILTRITE™
HANDLERS**

NORTHSHORE MANUFACTURING

Builrite Handler Model 60 Back of Cab/Tail Mount



STANDARD SPECIFICATIONS & FEATURES

Lift Capacity (Less Attachment)

5,800 Lbs. @ 10' Radius
3,200 Lbs. @ 15' Radius
2,000 Lbs. @ Full Reach (18'4")

Boom Data (18'4" Boom)

Reach-Horizontal 18'4"
Reach-Vertical 29'8"
One 9'10" Main boom
One 8'6" Jib boom
High yield structural tube construction
2" Boom pivot and cylinder pins with Magnesium Bronze bushings at all pivot points

Boom Cylinders

One (1) 6" x 24" x 2-1/2" rod-Main boom cylinder
One (1) 5" x 24" x 2-1/2" rod-Jib boom cylinder

Double-acting heavy wall, honed steel tubing, with cushioned stops

Cylinders have wear rings on pistons and glands
Heat treated cylinder rods with heavy chrome plating

Swing System

550 Degree non-continuous rotation with mechanical stops
27" Diameter turntable bearing
Powered by One (1) swing motor and planetary gear box

Platform

Rotating operator's platform
Fold-down adjustable seat
Joystick controls
Foot controlled swing
Safety guard rail around operator

Main Frame

A-Frame style
High tensile steel
Overall height is 13'4" mounted on a 40" truck frame
Subframe and stabilizers are combined together to form one clean, simple weldment

Stabilizers

Telescoping with Two (2) 3" x 43" x 2" rod cylinders
Load lock valves on cylinders
Control valves are mounted under seat
Dual Heavy duty ladders

Hydraulic Reservoir

42 Gallon loader frame mount, with suction and return line filters

Power Source

Power take-off from truck engine

Pump

Triple gear pump providing 20/20/10 GPM @ 1400 RPM

1750 PSI operating system

Control Valves

Stack type with joystick controls

Miscellaneous

Requires 26" of mounting space

Mounting bolts and support plates supplied

Approximate weight with standard equipment (less attachment and oil) is 5,800 Lbs.

Options/Accessories

20'4" straight boom

Oil cooler kit-Shipped loose

Paint color per customer preference

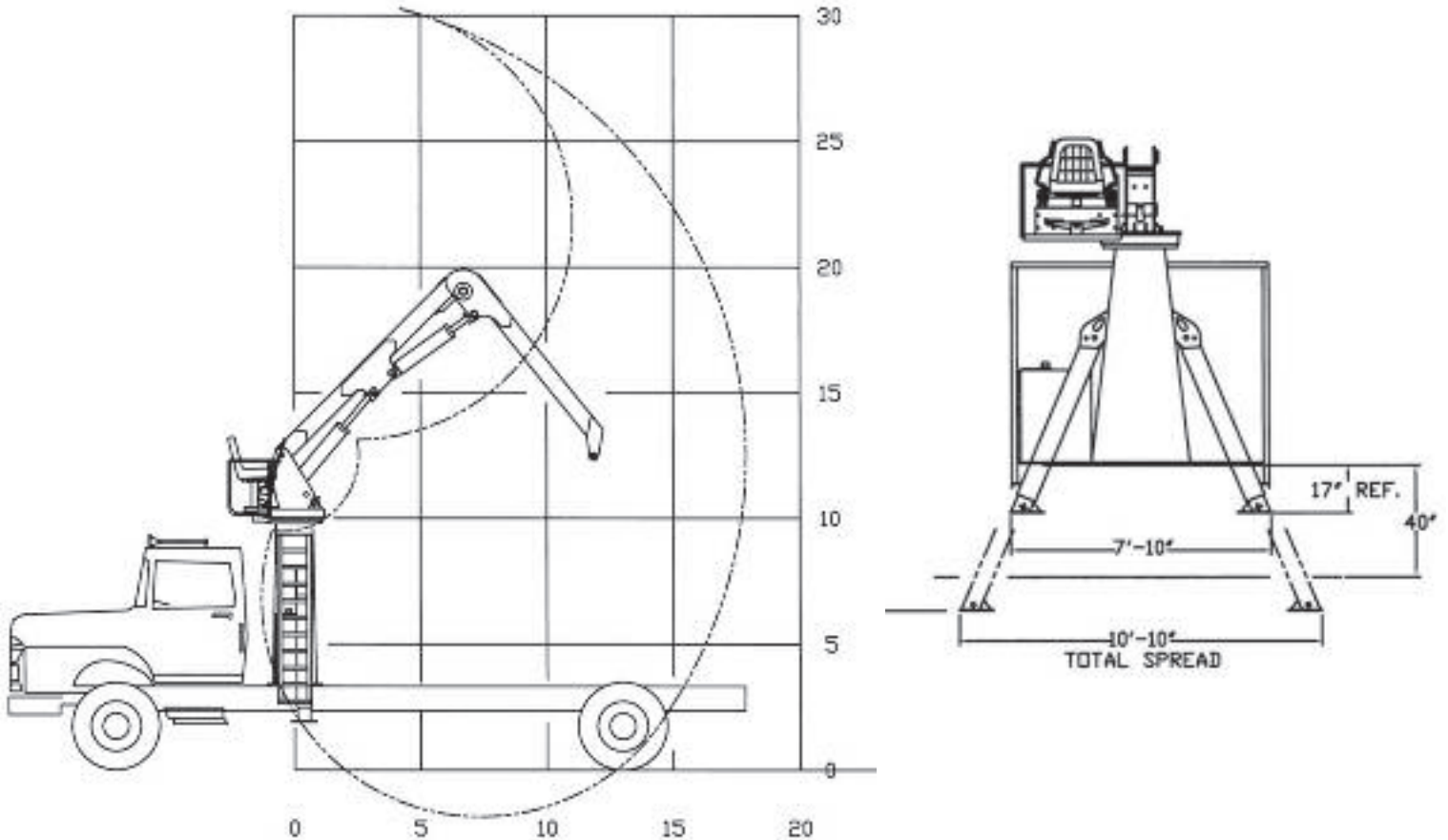

NORTHSHORE MANUFACTURING RESERVES THE RIGHT TO CHANGE SPECIFICATIONS AND PRICES WITHOUT NOTICE IN ORDER TO FOLLOW ITS POLICY OF CONSTANTLY STRIVING TO MANUFACTURE A BETTER PRODUCT WITHOUT INCURRING ANY LIABILITY TO PROVIDE THESE NEW FEATURES ON ANY UNITS PREVIOUSLY MANUFACTURED.

NORTHSHORE MANUFACTURING

530 RECYCLE CENTER DRIVE • P.O. BOX 273 • TWO HARBORS, MN 55616

PHONE: 218-834-5555 • FAX: 218-834-5556

WEB: WWW.BUILTRITEHANDLERS.COM • EMAIL: INFO@BUILTRITEHANDLERS.COM

FABRICATION • MACHINING • WELDING • MANUFACTURER OF

